

Hotline

**October
2013**



Efficient side gating

Production of technical parts for a vacuum cleaner

Pages 2 - 4



NEW product!

HPS III-MV
valve gate nozzle
for process-reliable multi-tip gating

Page 5



"Made in Germany" for global markets

EWIKON extends headquarters in Frankenberg Pages 6 - 8



BOSCH

GL-40

2000 W



Efficient Side Gating

Today, even engineering polymers and critical materials can be reliably processed thanks to efficient modern systems with direct side gating. A typical example is three injection moulds used by Bosch und Siemens Hausgeräte GmbH in Bad Neustadt/Saale, Germany, to produce technical parts for a vacuum cleaner.

Side gating of parts is often the ideal method for locating articles efficiently in the mould. Classically, this type of location is performed with slim, tubular plastic parts such as syringes, pipette tips or protective caps. It is often a common feature of the parts that they cannot be gated at an end face since that is where the orifices are disposed, and the remaining surfaces do not allow sufficient space for a gate. If one thinks in terms of hotrunner technology, then, in the simplest case, articles are achieved using partial hotrunner solutions with dead-end or tunnel gates, in the same way as with conventional coldrunner technology.

A whole range of different hotrunner solutions is now available for direct side gating, though they often require compromises to be made in the gate quality or the mould construction. This includes "cold slugs" in the article when edge gate nozzles are used, or split mould inserts in the case of rigid lateral hotrunner tips, which require a complicated mould design and can result in long downtimes for servicing. In addition, nozzles for side gating in the past were primarily designed for processing polyolefins and the applications were therefore more or less restricted to the aforementioned types of articles.

The HPS III-MH100 and MH200 nozzle series for direct gating eliminates this restriction to polyolefins. In the implementation of this solution, important items in the specification were high ease of maintenance and maximum versatility, with the ability to process a wide range of materials. Due to the relatively large mass of the nozzle, together with very good thermal conductivity of the tip inserts, engineering plastics such as polyamide, polyacetal, polybutylene terephthalate or polycarbonate can now be processed without restriction. In addition, thanks

Housing of the filter change indicator



■ **Material:**

PCTA

■ **Hotrunner system:**

4-drop system with
2 HPS III-MH112 nozzles,
2-drop version with 90°
tip inserts

to the melt channel profile within the nozzles, natural balancing is achieved together with minimized residence time. It is thus possible to process residence-time-critical materials, such as POM homopolymer or flame-resistant PA grades.

This versatility persuaded the injection moulder Zink Kunststoffwerk GmbH & Co. KG of Schwabach, Germany, to use side gating systems from EWIKON in three new moulds for components of filter change indicators in the GL 40 vacuum cleaner of Bosch und Siemens Hausgeräte GmbH. Since one of the parts, the transparent housing of the filter change indicator,

is made from the thermally sensitive material PCTA (a copolyester of terephthalic acid), the hotrunner solution had to have high process reliability. In the design of the mould, EWIKON was therefore involved from the start and supported Zink with the necessary preliminary investigations in the form of filling studies and material tests. The other parts are the housing and flap of the air by-pass valve, both made of ABS. All the moulds were built by Elasto Form KG, Hohenstadt, Germany.

The housing of the air by-pass valve is the simplest part for injection moulding purposes, since a large vertical

surface is available for side gating, and the shear-off effect can therefore be optimally exploited. Side gating was suitable since the housing must receive the flap in the interior and large orifices are present at the top and bottom ends. An eight-tip hotrunner with 90° tips (tip perpendicular to demoulding direction), consisting of two four-tip HPS III-MH nozzles in a linear design and a two-drop manifold. In all models of the HPS III-MH nozzle series, the tip inserts are accessible from the mould parting line, and so can be easily dismantled. The mould inserts therefore no longer need to be split, but can be made in one part – a particular advantage in this application. Since the housing is produced in various different models, which differ according to the position of the side retaining clip, interchangeable mould inserts are used, which allow an employer to exchange them easily, with just a short production interruption, when required.

■ **Versatile:** The HPS III-MH nozzle range offers different versions for shot weights up to 40 g per gate.



The mould for the housing of the filter change indicator replaces an existing cold runner mould. Newly created as a full hotrunner mould, it reduces cycle times while at the same time reducing costs through material savings, since the PCTA used is relatively expensive and cannot be reground. However, the very thermally sensitive material requires a channel profile with a favourable residence time behaviour. The engineers therefore opted for a compact 4-cavity mould, with a short, an-

Housing and flap of the air by-pass valve

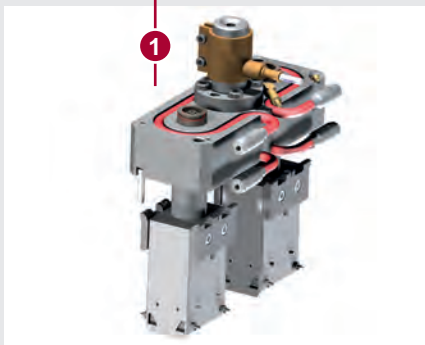
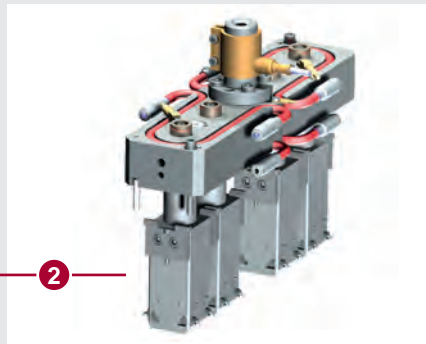

■ **Material:**

ABS for both parts

■ **Hotrunner system:**

- 1 **Housing:** 8-drop system with 2 HPS III-MH100 nozzles, 4-drop linear version with 90° tip inserts
- 2 **Flap:** 16-drop system with 4 HPS III-MH100 nozzles, 4-drop linear version with 60° tip inserts

Since this is not a typical article for side gating, gating could also have been realized with a conventional valve gate system; however, the desired 16-cavity design would have required both a larger mould construction and the mould would have been significantly more expensive because of the drive technology for the valve pins. This is where another general advantage of side gating becomes apparent. Since part of the melt channel profile is already integrated in the nozzle, small manifolds are sufficient even with multi-cavity moulds. As a result, the mould construction can be kept extremely compact.

In addition, multi-cavity nozzle concepts are an energy-efficient solution per se, since, during operation, they require less installed power per gate. Moreover, as already mentioned, smaller manifolds are used, particularly with a larger number of tips per nozzle. The number of contact points through which heat can flow into the mould during operation is reduced, and the energy consumption falls.

HPS III-MH series nozzles for side gating meet all the requirements regarding the position of the desired gating point and stable processing of the materials used. The thermally conductive tips, which can be easily interchanged from the parting line, make the moulds easily serviceable, and reduce downtimes during production. The last point is particularly important for maintaining constant part quality, since signs of wear or soiling of the gate can be quickly and easily eliminated.

gle-free melt channel profile that ensured that the material's residence time was not critically long at any time. The article is gated with two two-tip nozzles at the narrow side, since one core and one slide are present for each article. The core runs in the injection direction and the slide at a 90° angle to the injection direction. After assembly of the coloured signal piston and the associated spring, the housing is closed via a film hinge. The selected two-tip nozzles in radial design are highly suitable for moulds with slide mechanism, and permit a compact mould construction.

The flap of the air by-pass valve does not meet any of the classical side-gating situations. The gating point is close to the parting line and, with a part thickness of 2 mm, only a short shear surface is present. To allow neat shearing off, the gating point was chosen very small, at 0.8 mm. Tip inserts angled at 60° permit the gating position to be achieved without the gating position being changed significantly. The system is designed with 16 cavities. Four linear HPS III-MH nozzles are used in 4-tip design, with a straight, naturally balanced 4-drop manifold.

Contact

BSH Bosch und Siemens Hausgeräte GmbH
97616 Bad Neustadt / www.bsh-group.de

Zink Kunststoffwerk GmbH & Co. KG
91126 Schwabach / www.zink-kunststoffwerk.de/

Elasto Form KG
91224 Hohenstadt / www.elasto-form.de

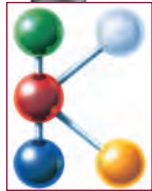
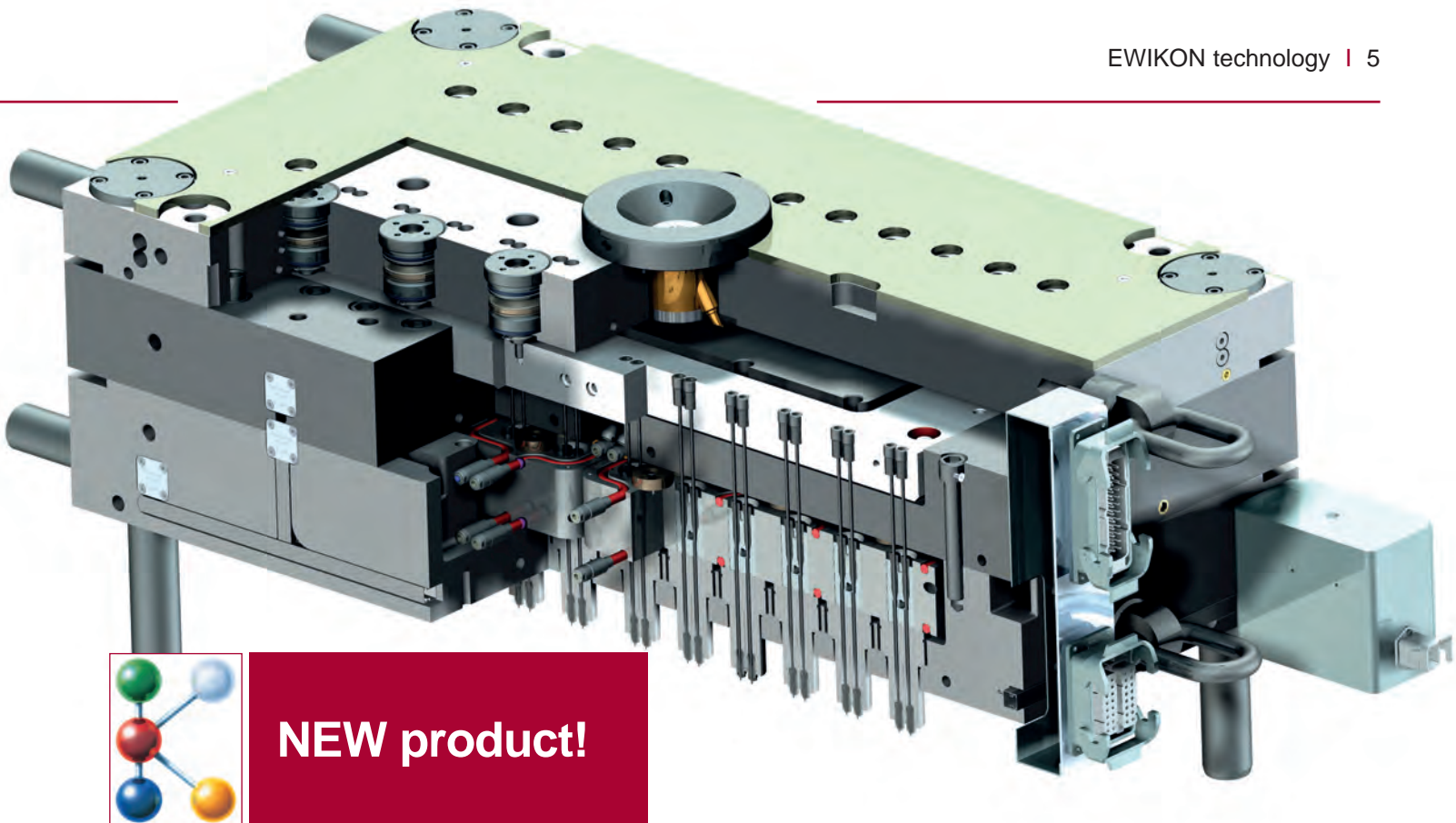

NEW product!

Process-Reliable Multi-Tip Valve Gating

The new HPS III-MV features a special technology which compensates the thermal expansion of the nozzle body and allows a reliable operation with minimum valve pin wear.

The new multi-tip valve gate nozzle is the ideal solution for applications where a part needs to be multi-gated with high process reliability and a perfect gate quality. The nozzle is available in two- or four-drop version. Each gate is fed by a separate melt channel. A minimum distance of 13 mm between the gates is possible. With its relatively large melt channel diameter of 6 mm the nozzle is particularly suited for applications where higher shot capacity are needed as for example the processing of poor-flow materials or engineering plastics.

A special design eliminates a common problem of comparable multi-tip nozzle concepts. Radial thermal expansion of the nozzle body leads to compressive stress on the sealing surfaces near the gate. This may cause valve pin deflection resulting in a higher wear of the gate and unacceptable gate vestiges on the moulded parts. The EWIKON multi-tip valve gate nozzle compensates for most of the



■ **Low-wear operation:** A special vertical groove in the nozzle body compensates for the radial thermal expansion. The valve pin load remains uncritical.

radial thermal expansion by an expansion groove machined into the nozzle body. It ensures that the valve pin load remains uncritical. On the manifold side the fully balanced EWIKON element technology is used. The output elements which are placed over the nozzles feature a special flow channel

layout with two or four melt outlets according to nozzle type and one valve pin seal per channel. The valve pins are actuated via a synchronous plate system.



Hotrunner System Solutions "Made in Germany"

EWIKON has been producing innovative, custom-made hotrunner technology in Frankenberg for more than 30 years. Extensive investment in machinery as well as expansions of the production and office area have set the course for the company's successful development.

For more than 30 years EWIKON has been a synonym for innovative hotrunner technology of utmost quality. Thanks to our premium products and extensive service we have established ourselves as one of the leading hotrunner manufacturer on the world markets. EWIKON hotrunner systems are used to ensure stable production processes and savings in material, time and energy in all important industries, from packaging and medical to automotive. Our core area of expertise is custom-made, innovative hotrunner solutions. These enable the customer

to find a suitable mould layout anytime and often form the basis for new solutions to produce injection-moulded parts in a more efficient way.

The headquarters located in Frankenberg is the centre of all EWIKON activities worldwide. It incorporates the R&D, design, production and sales & service departments where more than 230 highly qualified people work – with tendency to rise. After constructing a 1,000 m² large assembly hall in 2008 the main building was extended by another 1,200 m² in 2012.

This spacious annex contains a larger production area, personnel facilities and new offices for the sales and design departments. These offices are located close to each other to facilitate communication and coordination regarding the processing of orders. The extended production area amounts to more than 4,000 m² where both hotrunner components and complete hot halves are manufactured. To meet the high demands on quality EWIKON manufactures exclusively in Germany with a high level of in-house production. The production team consists of well-skilled workers which have latest manufacturing technologies at their disposal. More than 10 million euros have been invested to modernise the state-of-the-art ma-



■ **EWIKON headquarters in Frankenberg:** After extension of the main building new offices for the sales (top right) and design department as well as a further enlarged production area are available.

chinery over the past 10 years. It contains complex machining centres for combined turning, milling and drilling operations in one step as well as high-speed milling machines for superfinish machining and high-precision special machines to finish rotation-symmetric components.

To guarantee smooth job flow an integrated inventory and plant data collection system controls all processes – from quotation and order pro-

cessing in the sales department through production planning and control to dispatch of the goods.

A quality management system according to DIN EN ISO 9001:2008 with constant controls and functional tests makes sure that the high EWIKON quality standards are consequently adhered to.

Being an innovation and technology leader on the global hotrunner market EWIKON relies on continuous new

and further development. Our aim is to further improve existing products as well as to develop new approaches to support our customers in introducing new technologies or in optimising existing concepts. This is why our in-house R&D department with 12 permanent employees can make use of an autarkic prototype production, equipped with modern milling, turning, eroding and laser welding technology. Another important element of our busi-



■ **Efficient production:** The high-precision hotrunner components are produced using state-of-the-art machinery on a production area of more than 4,000 m². An integrated inventory and plant data collection system controls all processes.



■ **Guaranteed quality:**
A quality management system according to DIN EN ISO 9001:2008 monitors all processes (top).

■ **Customer service:**
Fluid bed cleaning system for thermal cleaning of hotrunner components (right).



ness activities is our quick and flexible customer service.

The EWIKON application technology department with 10 employees, 3 of which stationed abroad, coordinates and performs service interventions. If required, they support our customers in starting up systems and guarantee a quick and worldwide on-site support in the event of possible failures.

Our technical centre is equipped with 3 modern injection moulding machines. It is available for our customers

to carry out material tests and newly developed hotrunner solutions can also be tested here.

Our service department with 12 employees is in charge of preventive maintenance, repair and overhaul of customer systems.

A special service offered here is the modern fluid bed cleaning system where hotrunner components, for example manifold systems, can be cleaned thermally.

To learn more about our products and our worldwide sales network please visit our website www.ewikon.com

EWIKON Heißkanalsysteme GmbH

Siegener Straße 35 • 35066 Frankenberg / Germany • Tel: (+49) 64 51 / 50 10
Fax: (+49) 64 51 / 50 12 02 • E-mail: info@ewikon.com • www.ewikon.com